



## Early atmospheric detection of carbon dioxide from carbon capture and storage sites

Nasrin Mostafavi Pak, Ofelia Rempillo, Ann-Lise Norman & David B. Layzell

**To cite this article:** Nasrin Mostafavi Pak, Ofelia Rempillo, Ann-Lise Norman & David B. Layzell (2016) Early atmospheric detection of carbon dioxide from carbon capture and storage sites, Journal of the Air & Waste Management Association, 66:8, 739-747, DOI: [10.1080/10962247.2016.1176084](https://doi.org/10.1080/10962247.2016.1176084)

**To link to this article:** <http://dx.doi.org/10.1080/10962247.2016.1176084>



Published with license by Taylor & Francis. ©  
Nasrin Mostafavi Pak, Ofelia Rempillo, Ann-Lise Norman, and David B. Layzell



Accepted author version posted online: 22  
Apr 2016.  
Published online: 22 Apr 2016.



Submit your article to this journal [↗](#)



Article views: 631



View related articles [↗](#)



View Crossmark data [↗](#)

## Early atmospheric detection of carbon dioxide from carbon capture and storage sites

Nasrin Mostafavi Pak<sup>a</sup>, Ofelia Rempillo<sup>a</sup>, Ann-Lise Norman<sup>a</sup>, and David B. Layzell<sup>b</sup>

<sup>a</sup>Department of Physics and Astronomy, University of Calgary, Calgary, Alberta, Canada; <sup>b</sup>Canadian Energy Systems Analysis Research (CESAR) Initiative and Department of Biological Sciences, University of Calgary, Calgary, Alberta, Canada

### ABSTRACT

The early atmospheric detection of carbon dioxide (CO<sub>2</sub>) leaks from carbon capture and storage (CCS) sites is important both to inform remediation efforts and to build and maintain public support for CCS in mitigating greenhouse gas emissions. A gas analysis system was developed to assess the origin of plumes of air enriched in CO<sub>2</sub>, as to whether CO<sub>2</sub> is from a CCS site or from the oxidation of carbon compounds. The system measured CO<sub>2</sub> and O<sub>2</sub> concentrations for different plume samples relative to background air and calculated the gas differential concentration ratio (GDCR =  $-\Delta O_2 / \Delta CO_2$ ). The experimental results were in good agreement with theoretical calculations that placed GDCR values for a CO<sub>2</sub> leak at 0.21, compared with GDCR values of 1–1.8 for the combustion of carbon compounds. Although some combustion plume samples deviated in GDCR from theoretical, the very low GDCR values associated with plumes from CO<sub>2</sub> leaks provided confidence that this technology holds promise in providing a tool for the early detection of CO<sub>2</sub> leaks from CCS sites.

*Implications:* This work contributes to the development of a cost-effective technology for the early detection of leaks from sites where CO<sub>2</sub> has been injected into the subsurface to enhance oil recovery or to permanently store the gas as a strategy for mitigating climate change. Such technology will be important in building public confidence regarding the safety and security of carbon capture and storage sites.

### PAPER HISTORY

Received September 27, 2015  
Revised February 25, 2016  
Accepted April 2, 2016

### Introduction

To reduce greenhouse gas (GHG) emissions, carbon dioxide (CO<sub>2</sub>) from fossil fuel combustion can be concentrated, compressed, and injected into the subsurface for long-term storage (Metz et al., 2005). Such carbon capture and storage (CCS) technologies include economically beneficial uses for the CO<sub>2</sub> in enhanced oil recovery (EOR; Alvarado and Manrique, 2010) or simply a disposal strategy involving depleted gas and oil wells, or storage in deep saline aquifers (White et al., 2003).

Carbon dioxide leakage from geological storage sites is a matter of concern. Leaked CO<sub>2</sub> can contaminate shallow aquifers and surface water bodies and eventually reach the atmosphere with potential adverse impacts on ecosystem and human health (Keating et al., 2013). To gain and preserve public support for CCS, it will be necessary to implement technologies for the early detection and rapid mitigation of CO<sub>2</sub> from storage sites (Bruant et al., 2002; Verkerke et al., 2014).

In 2008, the Government of Alberta committed to reduce greenhouse gas emissions by 50 Mt/yr by 2020

and 200 Mt/yr by 2050, with CCS accounting for 139 Mt CO<sub>2</sub>/yr by 2050 (Alberta Energy, 2009). Assuming this goal is met through a linear increase in CCS in the province beginning in 2017 (i.e., 4.1 Mt/yr of new CCS storage each yr) at a leak of 0.001%/yr (Metz et al., 2005), the total flux to the atmosphere would be ca. 600 L CO<sub>2</sub>/min (569 t CO<sub>2</sub>/yr) in 2022, and 40 times that in 2050. Throughout this paper, leak rates will be described in units of L/min to emphasize that detection of relatively small rather than large leaks is the focus of the study. Although leaks from CCS are likely to be distributed across the province, a technology to find point source leaks in the range of tens to hundreds of L/min would be valuable in permitting early remediation of the site and to build public confidence for the technology.

CCS leaks can be detected at local sites by monitoring soil or atmospheric CO<sub>2</sub> concentrations (Cohen et al., 2013; Schutz et al., 2013; Verkerke et al., 2014), whereas leak detection can involve the use of chemical tracers (Myers et al., 2013). At all scales, including global, ratios of gases or their isotopes have been proposed as strategies for identifying CO<sub>2</sub> leaks from CCS

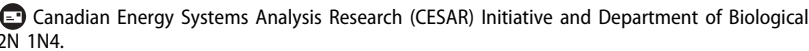
**CONTACT** David B. Layzell  [dlayzell@ucalgary.ca](mailto:dlayzell@ucalgary.ca) 

Published with license by Taylor & Francis. © Nasrin Mostafavi Pak, Ofelia Rempillo, Ann-Lise Norman, and David B. Layzell

This is an Open Access article. Non-commercial re-use, distribution, and reproduction in any medium, provided the original work is properly attributed, cited, and is not altered, transformed, or built upon in any way, is permitted. The moral rights of the named author(s) have been asserted.

sites (Keeling et al., 2011; Romanak et al., 2013; Ma et al., 2013).

The present study reports on a mobile measurement method to both detect atmospheric CO<sub>2</sub> plumes and identify whether the CO<sub>2</sub> in the plume may have originated from a pure CO<sub>2</sub> source (such as that from a CCS reservoir or a CO<sub>2</sub> pipeline), as opposed to biological respiration/combustion, or the combustion of fossil fuels. This study focuses on the precision of measurements of the ratio of  $\Delta O_2$  to  $\Delta CO_2$  for various combustion processes relative to background air and a comparison of calculated and experimentally measured ratios. Although elevated concentrations of 50–200 ppm CO<sub>2</sub> are easily detectable against a background of 400 ppm CO<sub>2</sub>, measuring a similar decrease in O<sub>2</sub> concentration is more challenging, since the background O<sub>2</sub> in air is 20.9% (209,460 ppm).

Methods capable of resolving such small changes in O<sub>2</sub> include interferometric analysis (Keeling, 1988) and measurements based on mass spectroscopy (Bender et al., 1994). These methods require intensive field campaigns and the equipment used for the determinations are expensive in comparison with the differential fuel cell technology. An alternative fuel cell technology was used to create a differential oxygen analyzer (DOX) system (Willms et al., 1997; Kettlewell, 2004) for measurements of photosynthetic and respiratory quotients in biological systems and commercialized by Qubit Systems Inc. (Kingston, Canada). In a recent study, Van Leeuwen and Meijer (2015) also used fuel cell technology at a fixed location for continuous measurements of O<sub>2</sub> to detect CCS leaks downwind. Compared with other measurement methods for O<sub>2</sub>, the DOX technology is mobile, more cost-effective to build and operate, but lacks the sensitivity of mass spectrometry. However, the resolution of the DOX technology met our requirements for measuring O<sub>2</sub> concentration differentials in plume samples. The DOX had a resolution of 0.4 Pa (~4 ppm) against background air with accuracy of 0.2 Pa (~2 ppm) (Kettlewell, 2004).

## Experimental methods

The ultimate goal of this work is to build a portable, field-based system that (a) detects and samples CO<sub>2</sub> plumes in air, (b) analyses them for differential O<sub>2</sub>/CO<sub>2</sub> ratios relative to bulk air to determine whether the CO<sub>2</sub> may have come from a CCS storage site, and if so, (c) combine this information with information on wind speed, direction, and global positioning system (GPS) data to identify the approximate location of the potential leak. The prototype instruments build for this feasibility study involved a field-based detection/sampling system and a laboratory-

based analytical system for measurement of the O<sub>2</sub>/CO<sub>2</sub> ratio to determine the origin of the CO<sub>2</sub> in the plume.

To test the laboratory-based analytical system, a number of gas samples were created by either mixing gases having different compositions or by sampling plumes from known combustion sources. The results were compared with theory. Also, a field study was carried out in which the plumes of air downwind of a CO<sub>2</sub> source (dry ice) were detected and sampled and then analyzed in the laboratory.

## The analytical system

The gas analysis system shown in Figure 1 was built to measure the differences in the CO<sub>2</sub> and O<sub>2</sub> concentrations between a reference gas having the composition of background air and samples containing CO<sub>2</sub>-enriched plume gas. A pump (model P651; Qubit Systems Inc., Kingston, ON) was used to draw two gas streams from an 86L reference gas bag (model 32310-314; VWR International, Radnor, PA). The gas streams flowed through two flow meters (model RMA-150; Dwyer Instruments, Michigan City, IN) and drying columns of magnesium perchlorate at a flow rate of 20–40 mL/min each before reaching the reference (R) and sample (S) sides of a differential oxygen analyzer (DOX; prototype version of model S104; Qubit Systems) that contained sensor outputs for absolute (PA, Figure 1) and differential (PD, Figure 1) pressure, absolute (OA<sup>r</sup> and OA<sup>s</sup>, Figure 1) and differential (OD, Figure 1) oxygen, and numerous temperatures (not shown).

The gas stream flowing through the sample side of the DOX was also provided to the sample cell of an infrared gas analyzer (IRGA; model LI-7000; Licor Instruments, Lincoln, NB) setup so that the reference cell was maintained in CO<sub>2</sub>-free air and the voltage output was proportional to the absolute CO<sub>2</sub> concentration (CA, Figure 1). The sensor outputs from the DOX and the IRGA were converted from analog to digital signals (DAQcard-6036E; National Instruments, Vaudreuil-Dorion, QB) and monitored by computer running gas exchange software (model C950; Qubit Systems).

The gas analysis system was used to quantify the differences in CO<sub>2</sub> ( $\Delta CO_2$ ) and O<sub>2</sub> ( $\Delta O_2$ ) concentrations between a reference gas of ambient air ( $fO_{2i} = 0.209$  and  $fCO_{2i} = 0.0004$ ) and a sample gas that was typically enriched in CO<sub>2</sub> and depleted in O<sub>2</sub> relative to the reference gas. The measured gas differential concentration ratio (GDCR<sup>m</sup>) was defined as

$$\text{GDCR}^m = -\Delta O_2 / \Delta CO_2 \quad (1)$$

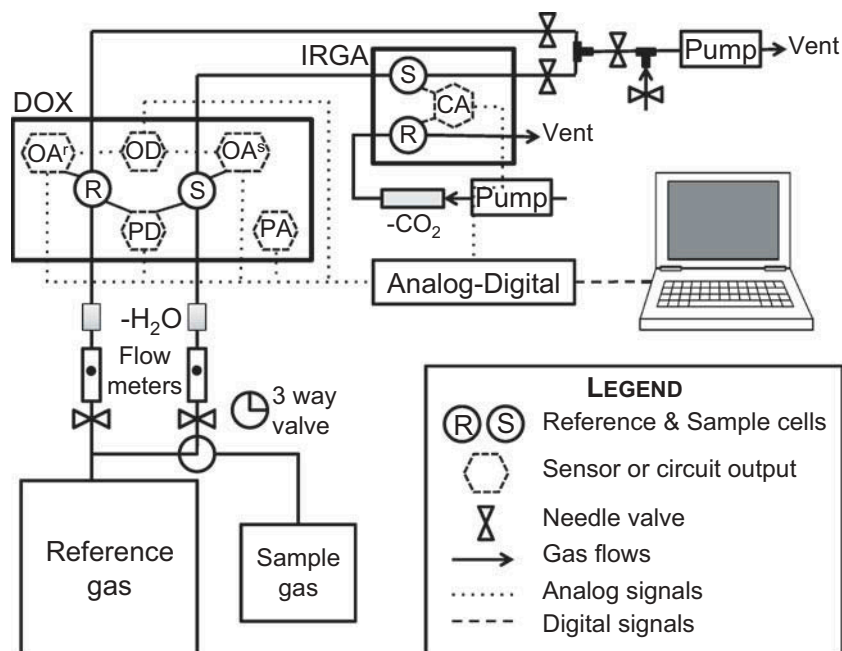

**Figure 1.** Schematic diagram of the gas analysis system used to measure the  $O_2$  and  $CO_2$  concentration differences between a reference gas (bulk air) and a sample/plume gas to calculate differences in the oxygen ( $\Delta O_2$ ) and carbon dioxide ( $\Delta CO_2$ ) concentrations. DOX, differential oxygen analyzer; IRGA, infrared gas analyzer;  $OA^r$  and  $OA^s$ , absolute  $O_2$  sensor for reference and sample gas, respectively; OD, differential  $O_2$  output; PA and PD, absolute and differential pressure sensors, respectively; CA, absolute  $CO_2$  sensor output.

### Preparation of gas samples for testing

To create gas samples that would be typical of that found in  $CO_2$ -enriched plumes in air, two approaches were used and combined with theoretical calculations to compare measured and predicted values for GDCR.

### Gas mixing

A volume of an initial gas ( $V_i$ ) having a known fractional  $O_2$  ( $fO_{2i}$ ) and  $CO_2$  ( $fCO_{2i}$ ) composition was assumed to mix with a smaller volume of injected gas ( $V_{inj}$ ) with a known fractional  $O_2$  ( $fO_{2inj}$ ) and  $CO_2$  ( $fCO_{2inj}$ ) composition. The predicted gas differential concentration ratio (GDCR<sup>P</sup>) after injection was calculated as

$$GDCR^P = - (fO_{2inj} - fO_{2i}) / (fCO_{2inj} - fCO_{2i}) \quad (2)$$

Assuming the initial gas was bulk air ( $fO_{2i} = 0.209$  and  $fCO_{2i} = 0.0004$ ) and the injected gas was pure  $CO_2$ , a GDCR<sup>c</sup> value of 0.209 was calculated. If the injected gas was changed to 10.15%  $CO_2$  in  $N_2$ , a GDCR<sup>c</sup> value of 2.07 was calculated.

### Combustion of carbonaceous material

The complete oxidation of a carbonaceous compound can be described by eq 3:

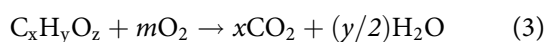

where  $m$  represents the moles of  $O_2$  consumed and  $x$ ,  $y$ , and  $z$  are the atom-moles of C, H, and O in the molecule. Values for  $m$  can be calculated from the chemical formula for the carbonaceous compound using eq 4:

$$m = x + (y/4) - (z/2) \quad (4)$$

In the gas analysis system used here, the reference and sample gases are dried ( $H_2O$  removed) in a magnesium perchlorate column before being measured. Therefore, the  $(y/2)$  term makes no contribution to gas composition after combustion and the net gas exchange (NGE; mole/mole initial carbonaceous compound) associated with the reaction can be calculated as

$$NGE = -m + x \quad (5)$$

Assuming the carbonaceous compound is combusted in a gas with known initial fractional  $O_2$  ( $fO_{2i}$ ) and  $CO_2$  ( $fCO_{2i}$ ) concentrations, the predicted gas differential concentration ratio (GDCR<sup>P</sup>,  $pO_2/pCO_2$ ) is:

$$GDCR^P = - (-m - (fO_{2i} \times NGE)) / (x - (fCO_{2i} \times NGE)) \quad (6)$$

Table 1 shows the chemical reactions for complete oxidation of three carbon substrates tested in the present study, and for each provides the calculated GDCR<sup>P</sup> values. Note that eqs 3–6 can also be used to calculate GDCR<sup>P</sup> values for a  $CO_2$  leak into air (Table 1).

**Table 1.** Prediction of the gas differential concentration ratio (GDCR<sup>P</sup>) associated with the combustion of four carbonaceous compounds or CO<sub>2</sub> mixing with air.

Substrate	Chemical Reaction	Stoichiometric Ratio (O <sub>2</sub> Uptake/CO <sub>2</sub> Production)	Net Gas Exchange (NGE; moles)	Predicted GDCR <sup>P</sup> (ΔpO <sub>2</sub> :ΔpCO <sub>2</sub> )
Paper combustion	C <sub>6</sub> H <sub>10</sub> O <sub>5</sub> + 6O <sub>2</sub> → 6CO <sub>2</sub> + 5H <sub>2</sub> O	1.00	0	1.00
Gasoline combustion	C <sub>8</sub> H <sub>18</sub> + 12.5O <sub>2</sub> → 8CO <sub>2</sub> + 9H <sub>2</sub> O	1.56	-4.5	1.44
Propane combustion	C <sub>3</sub> H <sub>8</sub> + 5O <sub>2</sub> → 3CO <sub>2</sub> + 4H <sub>2</sub> O	1.67	-2	1.53
Methane combustion	CH <sub>4</sub> + 2O <sub>2</sub> → CO <sub>2</sub> + 2H <sub>2</sub> O	2.00	-1	1.79
Leakage of CO <sub>2</sub> into air	(no reaction)	0.00	1	0.21

Notes: See text and eqs 4–6 for details. Note that paper combustion is representative of wood combustion (e.g., forest fires).

### Measurement of GDCR<sup>m</sup> in prepared gases

Gas-impermeable bags (Tedlar 232-05, SKC Inc., Eighty Four, PA), having a volume of 86 L (reference) or 5 L (sample), were filled with outside air at the same time and away from any sources of CO<sub>2</sub>. The reference and sample bags were connected to the gas analysis system as shown in Figure 1 and the fractional CO<sub>2</sub> concentration (fCO<sub>2i</sub>) measured in the sample and reference bags. The fractional O<sub>2</sub> concentration in the reference bag was assumed to be 0.209 (fO<sub>2i</sub> = 0.209), and the DOX was used to measure the differential O<sub>2</sub> partial pressure (ΔpO<sub>2i</sub>; Pa) in the sample relative to the reference gas. Using known values for atmospheric pressure (PA; Pa), temperature (T), the fractional, partial pressure of a gas (pG; Pa) was converted to molar concentration (fG; ppm) using the following equation:

$$fG = (pG(T)/(PA) \times 10^6) \quad (7)$$

where G is an arbitrary gas molecule.

When the three-way valve on the gas analysis system (Figure 1) was set to draw both reference and sample gases from the reference bag, incremental amounts of pure CO<sub>2</sub> (fCO<sub>2inj</sub> = 1.0) or a gas with a fractional concentration of 10.15% CO<sub>2</sub> in N<sub>2</sub> (fCO<sub>2inj</sub> = 0.1015, fO<sub>2inj</sub> = 0; certified, Praxis Inc, Danbury, CT), were injected into the sample bag and mixed as described previously.

After each injection, the fractional CO<sub>2</sub> concentration (fCO<sub>2</sub>) was measured along with the O<sub>2</sub> concentration differential (ΔO<sub>2</sub>) relative to the reference gas bag. To obtain representative GDCR<sup>m</sup> values for each sample, triplicate measurements relative to the reference gas were made by switching the three-way valve between reference and sample gas inlets every 4 min. For the last 30 sec of each 4-min period, average values were recorded for the OD, CA, atmospheric pressure, and the pressure differential between sample and reference gases. Pressure differentials were used to correct the OD measurements. Changes in CO<sub>2</sub> partial pressure (ΔCO<sub>2</sub>) and differential O<sub>2</sub> partial pressure (ΔO<sub>2</sub>) relative to the reference gas were calculated, to permit the subsequent calculation of GDCR<sup>m</sup> using eq 1.

Figure 2 demonstrates the real-time, replicate measurements of the absolute CO<sub>2</sub> concentration and the O<sub>2</sub> differential concentration in a sample gas bag filled with reference gas before and after it received each of three serial injections (at 13, 32, and 55 min) of a gas containing 10.15% CO<sub>2</sub> in N<sub>2</sub>. Note that after each injection, a consistent stepwise change was observed in both the CO<sub>2</sub> and O<sub>2</sub> concentrations relative to the reference gas. Every 3–5 min, the gas streams being sampled by the analysis system could be switched, making it possible to obtain CO<sub>2</sub> differentials with a resolution of about 1 ppm and O<sub>2</sub> differentials with a resolution of about 5 ppm.

Laboratory experiments employing the same methodology were used to test the capability of the gas analysis system to measure the GDCR of plumes from different combustion sources. After capturing the plume gases, subsamples of it were sequentially injected

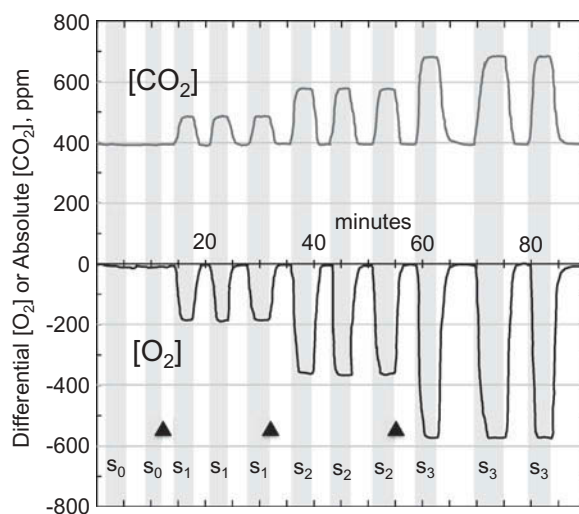

**Figure 2.** Output of the IRGA [CO<sub>2</sub>] and DOX [O<sub>2</sub>] (converted to absolute or differential concentrations, respectively), during a typical experimental run where the gas supplied to the sample cell of the DOX and IRGA was switched between a reference gas (clear background) and a sample gas (shaded background). The ~5-L sample gas bag was either identical in gas composition to the reference gas (S<sub>0</sub>) or the result of 0.3 mL (S<sub>1</sub>), 0.8 mL (S<sub>2</sub>), or 1.2 mL (S<sub>3</sub>) injections of 10.15% CO<sub>2</sub> in N<sub>2</sub> at the times denoted by the black triangles.

into a known volume (about 5 L) of reference gas to create a series of step change increases in the CO<sub>2</sub> differential relative to the reference gas. Subsamples were needed because the plume samples collected often exceeded the detection range of the instrument. The targeted steps for CO<sub>2</sub> differentials in the sample gas bag (relative to the reference gas) were 50–100 ppm, then 100–200 ppm, then 200–400 ppm CO<sub>2</sub>. Between each sequential injection, the gas sample was placed on the gas-exchange system to obtain a data set similar to that shown in Figure 2.

For methane combustion, gas samples were collected ~10–20 cm above the flame of a Bunsen burner consuming 99% methane (certified Praxair) and stored in a 5-L gas bag. Propane combustion gas samples were collected ~10–20 cm above the flame of a propane-fired barbeque. For biomass combustion, pieces of paper were burned in a furnace and gas samples were collected 10–50 cm above the flames. For gasoline combustion, sample bags were collected 30–50 cm away from an idling vehicle's tailpipe. A minimum of three replicate samples were taken for all materials except for gasoline where only two replicate samples were taken.

### Field sampling

Once the validity of the methodology had been tested through comparison of predicted (GDCR<sup>P</sup>) and measured (GDCR<sup>M</sup>) values for GDCR, a field trial was carried out to resemble a CO<sub>2</sub> leak under more “real-world” conditions. On September 7, 2012, six cubes of dry ice, 50 lbs (23 kg) each, weighed before and after the experiment to determine CO<sub>2</sub> flux, were placed on a wooden platform at a height of 15 cm above the ground in a soccer field located on the west campus of the University of Calgary. The location provided a flat and uniform surface far from buildings and major roads to prevent interference with other anthropogenic sources of CO<sub>2</sub>. Emissions started at 11 a.m. and measurements were completed by 7 p.m.

A portable (12 V DC) backpack gas monitoring and sampling system was built (not shown) consisting of an infrared CO<sub>2</sub> analyzer (model SBA-4 OEM; PP Systems Inc., Amesbury, MA) connected through an A/D convertor (model USB-6009 OEM; National Instruments, Austin, TX) to a laptop computer (model Toughbook 31; Panasonic, Secaucus, NJ) running software (Labview version 8.6, Student edition; National instruments). A low volume pump (750 mL/min; model NMP 09 B; KNF Neuberger Inc., Trenton, NJ) continuously sampled air through a

handheld 180-cm-long “wand” held approximately 40 cm off the ground and provided it to the CO<sub>2</sub> analyzer.

When a plume of 100–600 ppm above ambient was detected (or a background air sample was needed upwind of the CO<sub>2</sub> source), the computer was used to activate a high volume pump (9 L/min; model N 89 KTDC; KNF Neuberger) that collected air from the same location as the smaller pump was sampling and delivered it to a 5-L Tedlar gas bag. Typically, 5 L of gas was sampled over a 30-sec period. Air monitoring for CO<sub>2</sub> plumes was carried out between 1 and 100 m from the source, and the samples were typically collected between 9 to 20 m from the source where the CO<sub>2</sub> concentration was 100–600 ppm above ambient.

A large 85-L sample of background air was collected upwind from the dry ice at 10:00 a.m., and then smaller background air samples and CO<sub>2</sub> plume samples were taken between 10:00 a.m. and 6:30 p.m. local time, as shown in Figure 3 and described above. Air temperature ranged from 30 to 33 °C under low wind speed conditions. The average wind speed was 1 m/sec, and the average wind direction was from north to south. The gas samples were taken back to the laboratory for CO<sub>2</sub> and O<sub>2</sub> analysis using the gas analysis system described in Figure 1.

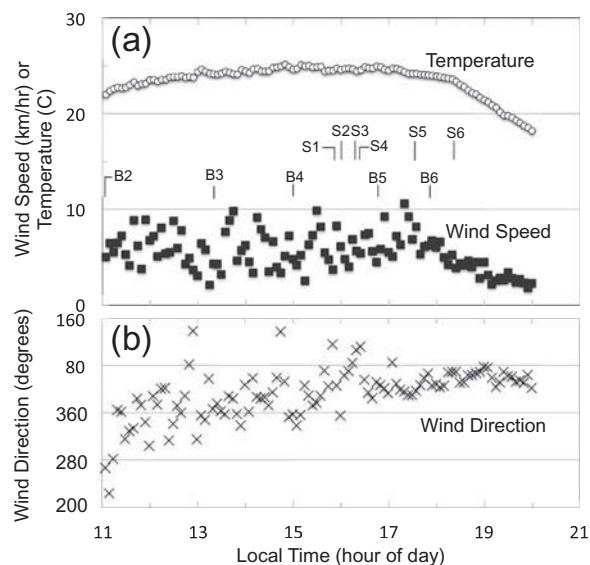

**Figure 3.** Ten-minute average temperature and wind speed (a) and wind direction (b) measured at University of Calgary weather station at the time of the field experiment. The sample times for collection of background air (B2–B6) and CO<sub>2</sub> plumes (S1–S6) are shown in the upper panel.

## Result and discussion

### Testing and calibrating the gas analysis system for GDCR<sup>m</sup> measurements

As shown in Figure 2, the gas analysis system was able to reproducibly measure the changes in the concentrations of O<sub>2</sub> and CO<sub>2</sub> in synthetic plume gas relative to background air in the range of 100–600 ppm. Although such a detection range is routine for CO<sub>2</sub> where the background atmospheric CO<sub>2</sub> concentration is ca. 400 ppm CO<sub>2</sub>, it is more challenging for O<sub>2</sub>, which has a background atmospheric concentration of about 20,900 ppm.

To generate the range of  $\Delta O_2$  and  $\Delta CO_2$  in the sample gas bags analyzed and presented in Figure 2, various quantities of a calibration gas having 10.15% CO<sub>2</sub> in N<sub>2</sub> were injected into a sample gas bag containing the reference gas. When independently calibrated DOX and IRGA analyzers were used to quantify the resulting  $\Delta O_2$  and  $\Delta CO_2$  values, the measured GDCR<sup>m</sup> values were within 5% of the calculated values for GDCR<sup>P</sup> that were obtained using eq 2 (data not shown). Consequently, we chose to use this gas mixing strategy to calibrate the DOX and lock it to an external, standards-based calibration of the IRGA. This calibration approach not only sped up and simplified the use of the instruments, but also made it possible to rapidly check calibration stability over time.

### Comparing GDCR<sup>m</sup> and GDCR<sup>c</sup> in gas plumes

Laboratory experiments were carried out to measure the GDCR<sup>m</sup> of either pure CO<sub>2</sub> or gas from plumes of CO<sub>2</sub> created through the combustion of carbonaceous material and compare these values with theoretical calculated GDCR<sup>c</sup> values. The results are provided in Figure 4.

The measured GDCR<sup>P</sup> values are a good match to the predicted GDCR<sup>P</sup> values, and are a better fit when the CO<sub>2</sub> and O<sub>2</sub> differentials were larger. This is not surprising, since instrument sensitivity becomes less of a measurement problem with higher differentials. The largest difference between predicted and measured GDCR is associated with methane combustion where the measured GDCR values are 10% higher than predicted (Figure 4E). That result may have been the result of incomplete combustion of the methane, leading to some O<sub>2</sub> consumption but the production of CO (rather than CO<sub>2</sub>) that would not be detected by the IRGA. Consequently, incomplete combustion would lead to a higher, rather than a lower GDCR ratio (Figure 4E) that could result in difficulties in differentiating combustion sources. It is worth noting that the combustion substrate was analytical grade methane, so it should not be contaminated by H<sub>2</sub> that could also account for the methane measurements of GDCR<sup>m</sup> being higher than predicted GDCR<sup>P</sup>. Of course, if natural gas were to be used, rather than pure methane,

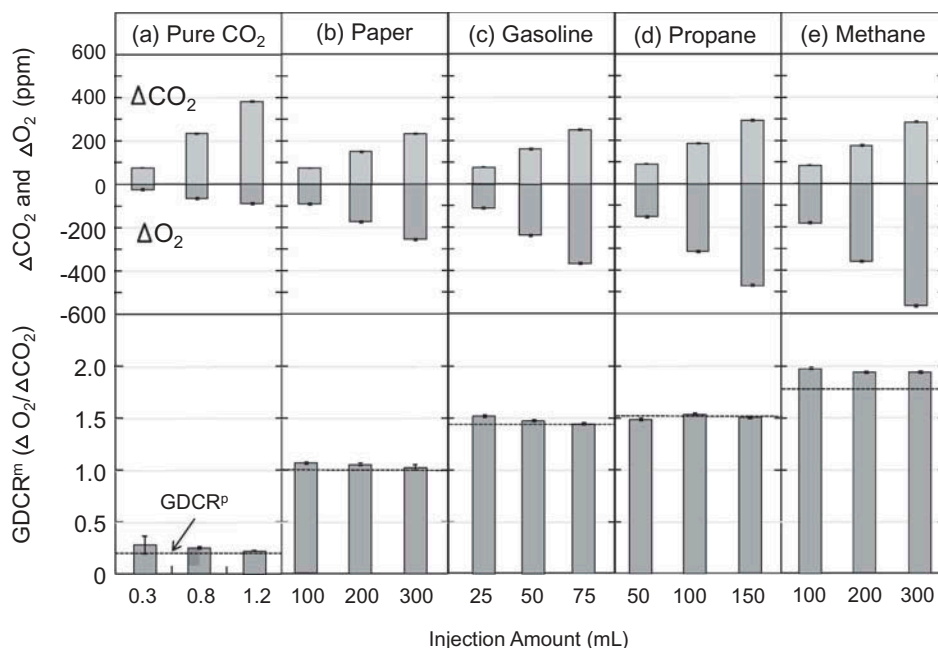

**Figure 4.** Measured  $\Delta O_2$  and  $\Delta CO_2$  and the resulting GDCR<sup>m</sup> values for sample gases generated by injected into a reference gas, pure CO<sub>2</sub> (a) or plume gases sampled from the combustion of paper (b), gasoline (c), propane (d), or methane (e). Each bar graph is shown  $\pm 1$  SE ( $n = 3$ ). The dotted horizontal lines in the lower panels show the predicted GDCR<sup>P</sup> values from eq 6 as presented in Table 1.

some variation around the  $\text{GDCR}^{\text{P}}$  value of 1.79 value would be expected.

Among the five possible plume sources tested here, the pure  $\text{CO}_2$  leak had both predicted and measured  $\text{GDCR}$  values that were the most different from the others plumes tested (Figure 4). However, there are many more possible sources of atmospheric  $\text{CO}_2$  plumes that need to be considered for their potential ability to give a false-positive detection of a  $\text{CO}_2$  leak.

Human breath, for example, would have a  $\text{GDCR}$  that reflects the carbon source being metabolized, so for carbohydrates, it would be 1.0, and for fats (e.g., linoleic acid,  $\text{C}_{18}\text{H}_{32}\text{O}_2$ ), the  $\text{GDCR}$  could be as high as 1.4.

Coal, on the other hand, may have an elemental composition that ranges from  $\text{C}_4\text{H}_4\text{O}$  (lignite) to  $\text{C}_{61}\text{H}_{24}\text{O}$  (anthracite), and the  $\text{GDCR}^{\text{P}}$  from their complete oxidation ranges from 1.12 to 1.09 (data not shown), values that are midway between biomass and oil combustion. Consequently, there should be no problem differentiating a  $\text{CO}_2$  leak ( $\text{GDCR}$  of 0.21) from coal combustion or human breath.

In the case of anaerobic metabolism, the  $\text{GDCR}^{\text{P}}$  is dependent on whether the end products are gases or not. For example, the process of anaerobic digestion typically results in the production of a biogas with a composition that ranges from an equimolar mix of  $\text{CO}_2$  and  $\text{CH}_4$  to 60%  $\text{CH}_4$  and 40%  $\text{CO}_2$  (Herout et al., 2011). In plumes from such biogas production, the resulting  $\text{GDCR}^{\text{P}}$  would range from 0.42 to 0.52, values that are at least 2-fold higher than what would be expected from a  $\text{CO}_2$  leak.

The one process that could deliver a false-positive  $\text{GDCR}^{\text{P}}$  value when monitoring for a  $\text{CO}_2$  leak is an anaerobic metabolism process leading to the production of ethanol fuel, such as that which occurs in a bioethanol fermentation facility. Since the method being developed here would be used to monitor known CCS sites, and the operator would presumably know the location of bioethanol facilities in the region, such false positives are likely to be very rare.

### Field measurements of $\text{CO}_2$ plumes from a simulated $\text{CO}_2$ leak

For the field study, the background atmospheric  $\text{CO}_2$  concentration was  $390 \pm 0.6$  (SE) ppm  $\text{CO}_2$ , and over the study period, it varied by no more than 2 ppm  $\text{CO}_2$  (data not shown). The background  $\text{O}_2$  concentration was assumed to be 209,000 ppm  $\text{O}_2$  and variations were measured as a differential relative to an air sample collected at the start of the study period.  $\text{O}_2$  concentrations in subsequent background air samples were within 18 ppm  $\text{O}_2$  of the initial sample and had a SE

of  $\pm 3$  ppm (data not shown). These results provided confirmation that there were no other major sources of  $\text{CO}_2$  near the measurement site.

Over the 9-hr study period, a portion of the dry ice sublimated releasing to the atmosphere an average of 116 L  $\text{CO}_2/\text{min}$  ( $= 110 \text{ t } \text{CO}_2/\text{yr}$ ). Assuming a leak rate of 0.001% per year (Metz et al., 2005), this magnitude of this leak would be associated with having about 11 Mt  $\text{CO}_2$  in storage.

Air samples downwind of the dry ice were monitored using a handheld wand connected to a portable monitoring and sampling system. When a  $\text{CO}_2$  plume was detected, a 4–5-L sample was collected over a 30-sec period. Subsequent laboratory analysis for  $\Delta\text{O}_2$  and  $\Delta\text{CO}_2$  showed concentrations of  $\text{CO}_2$  that were 100–350 ppm higher than background air, but the measured  $\text{O}_2$  concentration differential was much less (27–85 ppm; Figure 5).

The resulting  $\text{GDCR}^{\text{m}}$  values averaged  $0.26 \pm 0.2$ , or about 24% higher than the predicted  $\text{GDCR}^{\text{P}}$  of 0.21. This discrepancy could be attributed to a contribution of soil or plant respiration to the plume, or perhaps a contaminant in the dry ice that may have contributed to the dilution of  $\text{O}_2$  in the air resulting in a greater than expected  $\Delta\text{O}_2$ .

Even so, the measured  $\text{GDCR}^{\text{m}}$  values were consistent with a pure  $\text{CO}_2$  “leak,” and much lower than a

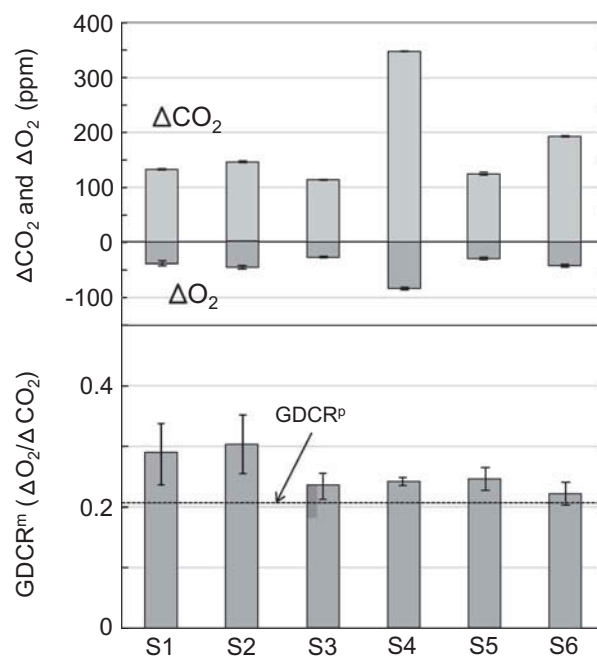

**Figure 5.** The  $\Delta\text{O}_2$ ,  $\Delta\text{CO}_2$ , and  $\text{GDCR}^{\text{m}}$  values measured in six different  $\text{CO}_2$  plumes (S1–S6) collected 9–20 m downwind of dry ice placed in a field to simulate a  $\text{CO}_2$  leak. Each bar graph is shown  $\pm 1$  SE ( $n = 3$ ). The dotted line in the lower panel shows the predicted  $\text{GDCR}^{\text{P}}$  value.



GDCR<sup>m</sup> generated from biological respiration or from biomass or fossil fuel combustion (Figure 4).

The 3–5-fold difference in the GDCR values associated with CO<sub>2</sub> leak and the GDCR values obtained from other combustion process (Figure 4) was considered sufficient to justify this methodology for the early detection of CO<sub>2</sub> leaks from CCS sites.

## Conclusion

This study has demonstrated the feasibility of detecting CO<sub>2</sub> leaks in ambient air downwind from CCS sites based on changes in the ratio of O<sub>2</sub> to CO<sub>2</sub> concentration differentials relative to background air using a mobile system. Large and statistically significant differences were observed in plumes with as little as a 100 ppm change in carbon dioxide concentrations.

Further work is needed to miniaturize the differential O<sub>2</sub> analyzer for a fully mobile field system and provide real-time measurements of  $\Delta O_2/\Delta CO_2$  ratios on sampled gas streams. If sensors and software were also integrated into the system to provide wind speed/direction and GPS coordinates, it should be possible to map elevated CO<sub>2</sub> mixing ratios and combine this with either back trajectory or inversion modeling to predict in real time, the GPS coordinates of a CO<sub>2</sub> leak from a CCS storage site. Moving towards those coordinates should increase the signal strength and permit the early atmospheric detection of CO<sub>2</sub> from CCS sites.

## Funding

This work was supported by a grant from the Institute for Sustainable Energy, Environment and Economy (University of Calgary) to Ann-Lise Norman and David B. Layzell. An NSERC Discovery Grant (RGPIN-2015-06628) to Ann-Lise Norman also contributed to the research. David B. Layzell is the co-inventor of two patents behind the DOX used in this study, and that instrument is the prototype of DOX analyzers that are currently being offered for sale by Qubit Systems Inc. (Kingston, ON, Canada), a company in which Layzell is part owner.

## About the authors

**Nasrin Mostafavi Pak** was a M.Sc. student in the Department of Physics and Astronomy at the University of Calgary.

**Ofelia Rempillo** was a postdoctoral fellow in the Department of Physics and Astronomy at the University of Calgary.

**Ann-Lise Norman** is an associate professor in the Department of Physics and Astronomy at the University of Calgary.

**David B. Layzell** is a professor and director of the Canadian Energy Systems Analysis Research (CESAR) Initiative in the Department of Biological Sciences at the University of Calgary.

## References

- Alberta Energy. 2009. *Talk about Carbon Capture and Storage*. Technical report. Edmonton, Alberta: Government of Alberta.
- Alvarado, V., and E. Manrique. 2010. Enhanced oil recovery: An update review. *Energies* 3:1529–1575. doi:10.3390/en3091529
- Bender, M.L., P.P. Tans, J.T. Ellis, J. Orchardo, and K. Habfast. 1994. A high precision isotope ratio mass spectrometry method for measuring the O<sub>2</sub>N<sub>2</sub> ratio of air. *Geochim. Cosmochim. Acta* 58:4751–4758.
- Bruant, R., A. Guswa, M. Celia, and C. Peters. 2002. Safe storage of CO<sub>2</sub> in deep saline aquifers. *Environ. Sci. Technol.* 36:240A–245A. doi:10.1021/es0223325
- Cohen, G., Loisy, C., Laveuf, C., Le Roux, O., Delaplace, P., Magnier, C., Rouchon, V., Garcia, B., and Cerepi, A. 2013. The CO<sub>2</sub>-Vadose project: Experimental study and modeling of CO<sub>2</sub> induced leakage and tracers associated in the carbonate vadose zone. *Int. J. Greenhouse Gas Control* 14:128–140. doi:10.1016/j.ijggc.2013.01.008
- Herout, M., J. Malafák, L. Kučera, and T. Dlabaja. 2011. Biogas composition depending on the type of plant biomass used. *Res. Agric. Eng.* 57:137–143.
- Keating, E.H., A.J. Hakala, H. Viswanathan, J.W. Carey, R. Pawar, G.D. Guthrie, and J. Fessenden-Rahn. 2013. CO<sub>2</sub> leakage impacts on shallow groundwater: Field-scale reactive-transport simulations informed by observations at a natural analog site. *Appl. Geochem.* 30:136–147. doi:10.1016/j.apgeochem.2012.08.007
- Keeling, R.F. 1988. Measuring correlations between atmospheric oxygen and carbon dioxide mole fractions: A preliminary study in urban air. *J. Atmos. Chem.* 7:153–176. doi:10.1007/BF00048044
- Keeling, R.F., A.C. Manning, and M.K. Dubey. 2011. The atmospheric signature of carbon capture and storage. *Philos. Trans. R. S. Lond. A* 369:2113–2132. doi:10.1098/rsta.2011.0016
- Kettlewell, B. 2004. The relationship between CO<sub>2</sub> and O<sub>2</sub> exchange during nitrification. Ph.D. dissertation, Department of Biology, Queen's University, Kingston, Ontario, 217 pp.
- Ma, D., J. Deng, and Z. Zhang. 2013. Correlation analysis for online CO<sub>2</sub> leakage monitoring in geological sequestration. *Energy Proc.* 37:4374–4382. doi:10.1016/j.egypro.2013.06.340
- Metz, B., O. Davidson, H. de Coninck, M. Loos, and L. Meyer. 2005. *Carbon Dioxide Capture and Storage*. IPCC Special Report on CO<sub>2</sub> Capture and Storage. Prepared by Working Group III of the Intergovernmental Panel on Climate Change. Technical Report. New York: Cambridge University Press.
- Myers, M., L. Stalker, B. Pejic, and A. Ross. 2013. Tracers—Past, present and future applications in CO<sub>2</sub> geosequestration. *Appl. Geochem.* 30:125–135. doi:10.1016/j.apgeochem.2012.06.001

- Romanak, K., G.W. Sherk, S. Hovorka, and C. Yang. 2013. Assessment of alleged CO<sub>2</sub> leakage at the Kerr farm using a simple process-based soil gas technique: Implications for carbon capture, utilization, and storage (CCUS) monitoring. *Energy Proc.* 37:4242–4248. doi:10.1016/j.egypro.2013.06.326
- Schütze, C., S. Lau, N. Reiche, U. Sauer, H. Borsdorf, and P. Dietrich. 2013. Ground-based remote sensing with open-path fourier-transform infrared (OP-FTIR) spectroscopy for large-scale monitoring of greenhouse gases. *Energy Proc.* 37:4276–4282. doi:10.1016/j.egypro.2013.06.330
- Van Leeuwen, C., and H.A.J. Meijer. 2015. Detection of CO<sub>2</sub> leaks from carbon capture and storage sites with combined atmospheric CO<sub>2</sub> and O<sub>2</sub> measurements. *Int. J. Greenhouse Gas Control* 41:194–209. doi:10.1016/j.ijggc.2015.07.019
- Verkerke, J.L., D.J. Williams, and E. Thoma. 2014. Remote sensing of CO<sub>2</sub> leakage from geologic sequestration projects. *Int. J. Appl. Earth Observ. Geoinform.* 31:67–77. doi:10.1016/j.jag.2014.03.008
- White, C.M., B.R. Strazisar, E.J. Granite, J.S. Hoffman, and H.W. Pennline. 2003. Separation and capture of CO<sub>2</sub> from large stationary sources and sequestration in geological formations—coalbeds and deep saline aquifers. *J. Air Waste Manage. Assoc.* 53:645–715. doi:10.1080/10473289.2003.10466206
- Willms, J.R., A.N. Dowling, Z.M. Dong, S. Hunt, B.J. Shelp, and D.B. Layzell. 1997. The simultaneous measurement of low rates of CO<sub>2</sub> and O<sub>2</sub> exchange in biological systems. *Anal. Biochem.* 254:272–282. doi:10.1006/abio.1997.2416